

Indusvent Clean Air Dust Extractor

RL 200



H3-Clean air dust extractors

For trade and industry, Indusvent offer certified clean-air extractors in various price and performance categories. The RL140, RL200 are mobile, save space and offer the highest level of performance and flexibility. All models achieve dust emissions of less than 0.1 mg/m³, in accordance with H3. The fan is uniquely positioned at the clean air side, thereby creating negative pressure throughout the filter preventing any dust escaping and eliminating fan impeller and casing wear.

Mobile Clean-Air Dust Extractor, GS inspected

All Indusvent Clean Air Dust Extractors are certified according to H3. The Indusvent clean air dust extractors will protect you from harmful dust particles in the workshop. The remaining dust in the air is reduced to less than 0.1mg/m³ BG inspected high quality filters (dust class M) and an extraction fan situated on the clean air side ensure this level of clean air.



Product Advantages

Dimensions

Total length (A)	1775 mm
Total length (A1)	1935 mm
Overall width (B)	898 mm
Total height (C)	2065 mm

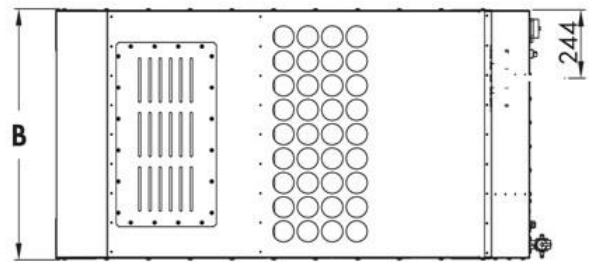
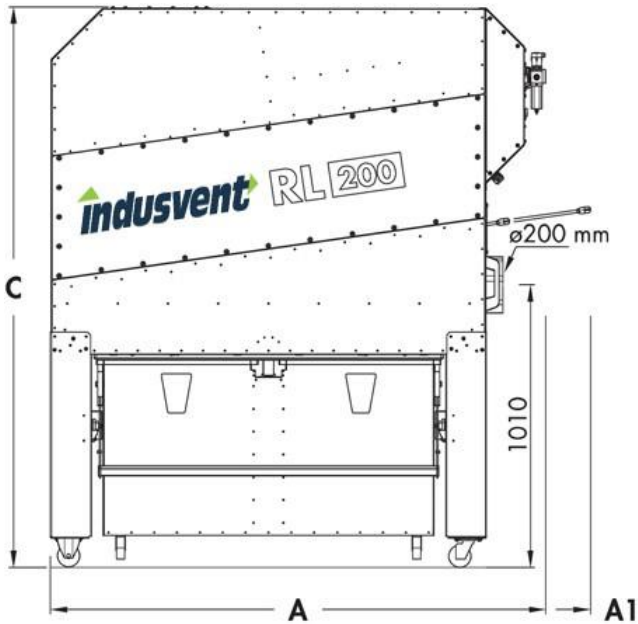

Standard Equipment

Technical specifications

Max. air volume	2600 m ³ /h
Static pressure at 20 m/s	2680 Pa
Extraction port	Ø200 mm
Cartridge filter - filter surface	20m ²
area Acoustic pressure	70 dB
Chip volume	2 x 200 Ltr
Extraction motor	3kW

Note: For technical processing reasons, uniform filling of the collection bins can not be guaranteed.

Manual filter cleaning as standard
Automatic cleaning available as an upgrade



The RL series dust extractors are explosion-proof

The extractors have been designed and are built in accordance with the EN 16770 standard (safety of woodworking machines - extractors for wood dust and shavings for internal use - safety requirements).

Due to the way in which the units have to be constructed, the device is not in danger of exploding.

Due to the design, a spark cannot lead to an explosion, but instead to a quick burn, where at no point the pressure inside the device will exceed 200 mbar.

As the type of unit has a pressure shock resistance of at least 200 mbar, no additional pressure relief measures are necessary.

The units have an ignition source-free construction, which means that they have no in-built ignition sources in the ATEX-zones and for that reason comply with ATEX 114.

Electrical Requirements By Customer

1 OFF 16 amp 4P + E Straight Plug 415v



<https://www.screwfix.com/p/abb-16a-4p-e-straight-plug-415v/2759x>

1 OFF 16 amp 4P + E Socket 415v



<https://www.screwfix.com/p/abb-16a-4p-e-surface-socket-415v/3669f>